

DIESEL

GRUPO ELECTRÓGENO | LOGUS



INFORMACIÓN GENERAL

| | |
|-----------------------------|----------------------|
| POT. STAND BY (KVA) | 125 |
| POT. PRIME (KVA) | 112 |
| FRECUENCIA (Hz) | 50 |
| VOLTAJE (V) | 380/220 |
| CONEXIÓN | 3P 4W Serie Estrella |
| FACTOR DE POTENCIA | 0.8 |
| POTENCIA MOTOR (Hp) | 150 |
| CAP. TANQUE DE COMBUST. (L) | 170 |
| PESO (Kg) | 1670 |
| DIMENSIONES (L*A*H mm) | 2920*1100*1420 |

| | |
|-----------------------------|---------------|
| MODELO | 125 BR SILENT |
| MARCA | LOGUS |
| TIPO DE ALIMENTACIÓN | DIESEL |



Tablero digital



Carga de combustible externa con medidor



Cargador de batería



Parada de emergencia

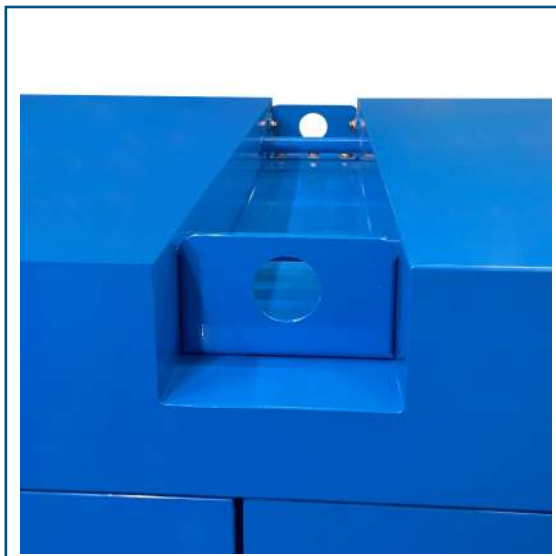

Cabina autoportante

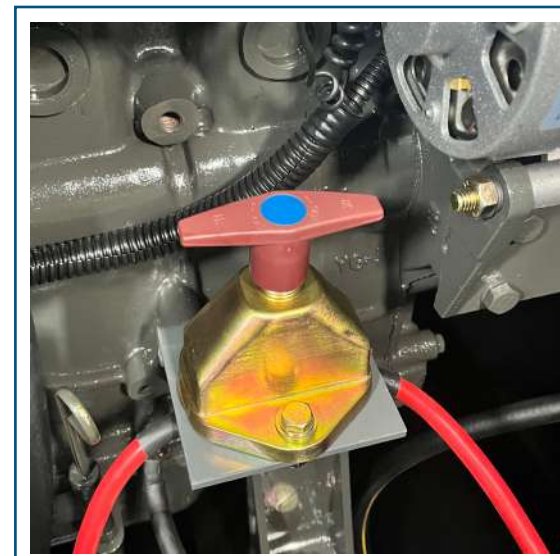

Cortacorriente

CONFIGURACIÓN GENERAL

| | | | |
|-----------------------|---------|-----------------------|--------------|
| PANEL DE CONTROL | Digital | INSONORIZACIÓN | Si |
| BATERÍA | Si | NIVEL SONORO | 75Db a 7 mts |
| TANQUE DE COMBUSTIBLE | Si | PROTECCIONES DE MOTOR | Si |

DATOS MOTOR

| | | | |
|---------------------|--------------------|----------------------------|------------|
| MOTOR DIESEL | R6105ZD/1500 R.P.M | POTENCIA | 150 Hp |
| CILINDROS | 6 | ASPIRACIÓN | Turbo |
| CAPACIDAD DE ACEITE | 16 Lts | CONSUMO AL 75% DE LA CARGA | 22.8 Lts/H |

DATOS ALTERNADOR

| | | | |
|------------|-----------|------------|------------------|
| ALTERNADOR | Brushless | EXCITACIÓN | Autoexcitado-AVR |
|------------|-----------|------------|------------------|

DIMENSIONES Y PESO

PESO **1670**kg

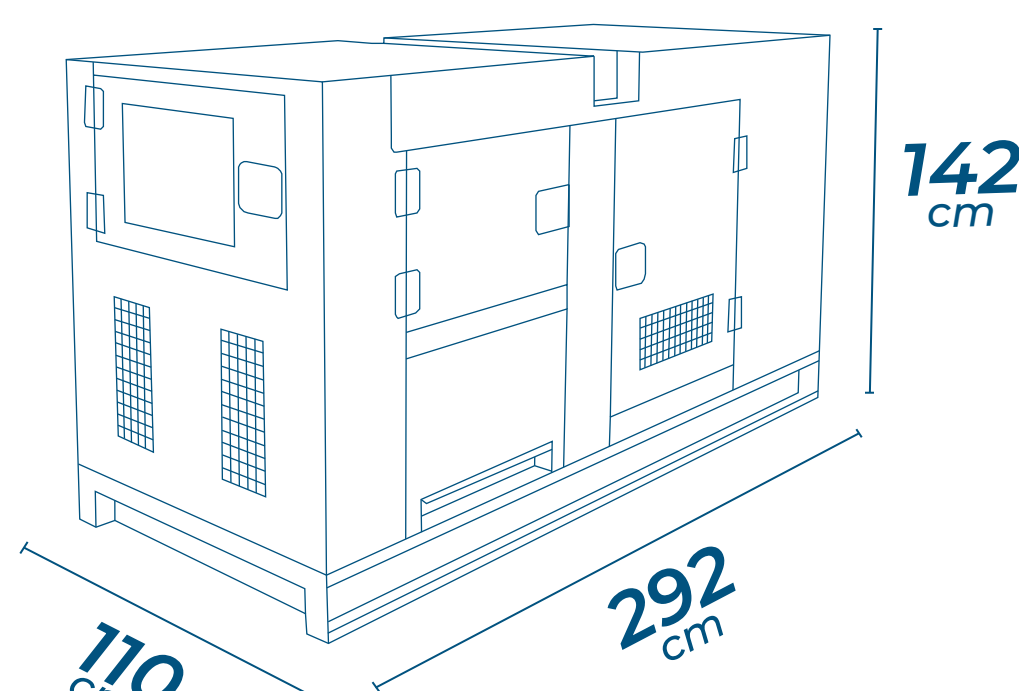

OPCIONALES

| | |
|--------------------|---------------|
| TABLERO AUTOMÁTICO | PRECALENTADOR |
| | |