

GRUPO ELECTRÓGENO | LOGUS



INFORMACIÓN GENERAL

|                        |                      |
|------------------------|----------------------|
| POT. STAND BY (KVA)    | 125                  |
| POT. PRIME (KVA)       | 112                  |
| FRECUENCIA (Hz)        | 50                   |
| VOLTAJE (V)            | 380/220              |
| CONEXIÓN               | 3P 4W Serie Estrella |
| FACTOR DE POTENCIA     | 0.8                  |
| POTENCIA MOTOR (Hp)    | 150                  |
| PESO (Kg)              | 1670                 |
| DIMENSIONES (L*A*H mm) | 2920*1100*1420       |

|                             |               |
|-----------------------------|---------------|
| <b>MODELO</b>               | 125 BR SILENT |
| <b>MARCA</b>                | LOGUS         |
| <b>TIPO DE ALIMENTACIÓN</b> | <b>GAS</b>    |
| <b>TTA</b>                  | INCLUIDO      |



Tablero digital



Parada de emergencia



Cargador de batería

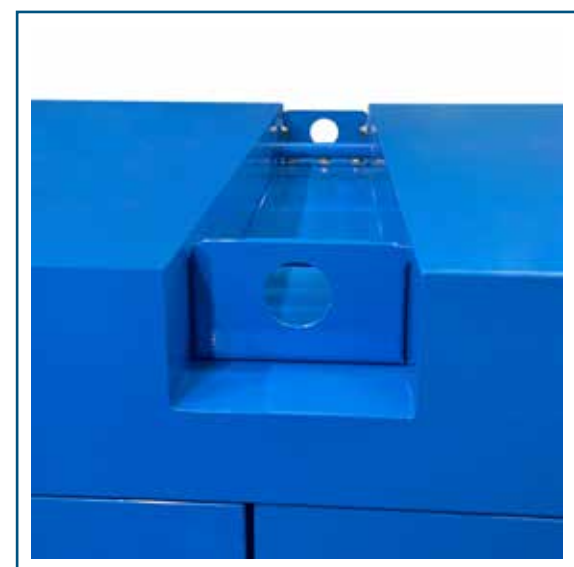

Cabina autoportante



Cortacorriente

CONFIGURACIÓN GENERAL

|                       |         |                |              |
|-----------------------|---------|----------------|--------------|
| PANEL DE CONTROL      | Digital | INSONORIZACIÓN | Si           |
| BATERÍA               | Si      | NIVEL SONORO   | 75Db a 7 mts |
| PROTECCIONES DE MOTOR | Si      |                |              |

DATOS MOTOR

|                     |                    |                            |         |
|---------------------|--------------------|----------------------------|---------|
| MOTOR               | R6105ZD/1500 R.P.M | POTENCIA                   | 150 Hp  |
| CILINDROS           | 6                  | ASPIRACIÓN                 | Turbo   |
| CAPACIDAD DE ACEITE | 16 Lts             | CONSUMO AL 75% DE LA CARGA | 25 m3/h |

DATOS ALTERNADOR

|            |           |            |                  |
|------------|-----------|------------|------------------|
| ALTERNADOR | Brushless | EXCITACIÓN | Autoexcitado-AVR |
|------------|-----------|------------|------------------|

DIMENSIONES Y PESO

PESO 1670kg

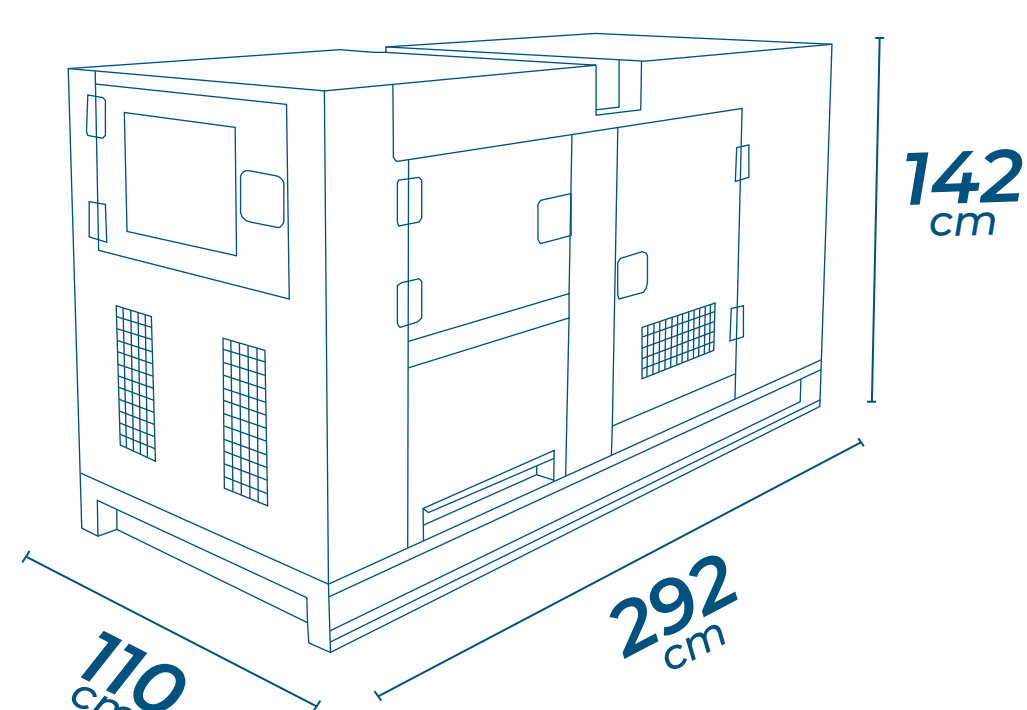

OPCIONALES

PRECALENTADOR

