

GRUPO ELECTRÓGENO | KIPOR



ESPECIFICACIONES TÉCNICAS

POTENCIA MÁX. (KVA)	10,5
TENSIÓN (V)	380/220
SALIDA (12V)	No
FRECUENCIA (Hz)	50
FACTOR DE POTENCIA	0,8
TIPO DE ARRANQUE	Eléctrico
MOTOR NAFTA	KG6900-OHV
POTENCIA (Hp)	20
CILINDROS	2
CILINDRADA (cc)	688
CAPACIDAD ACEITE (Lts)	1.3
CAPACIDAD TANQUE (Lts)	23
CONSUMO (Lts/h)	4.18
AUTONOMÍA (Hs)	5.5
NIVEL SONORO (dB a 7 mt)	77
DIMENSIONES (L*A*H mm)	910*600*760
PESO (Kg)	345
BATERÍA	Si

MODELO

KGE12E3

MARCA

KIPOR

TIPO DE ALIMENTACIÓN

NAFTA

DIESEL

KIPOR®

GRUPO ELECTRÓGENO | 10.5 KVA

CARACTERÍSTICAS PRINCIPALES



Tablero



Bornera de conexión



Medidor de combustible



Motor 20HP

DIMENSIONES Y PESO

PESO **345kg**

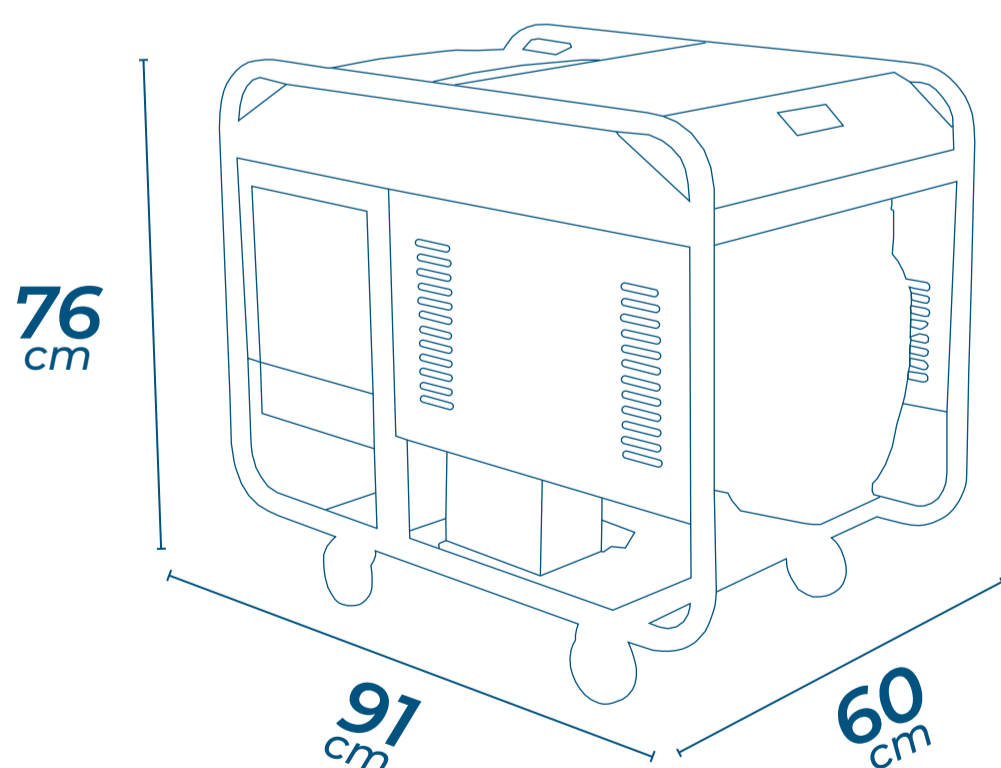

OPCIONALES

TABLERO AUTOMÁTICO

