

# KIPOR<sup>®</sup>

## KIPOR POWER OPERATION MANUAL

PLEASE READ THIS MANUAL CAREFULLY.  
IT CONTAINS IMPORTANT SAFETY INFORMATION.

[WWW.KIPOR.COM](http://WWW.KIPOR.COM)

# KIPOR<sup>®</sup>

WUXI KIPOR POWER CO., LTD.

Address: Beside Jingyi Rd, Third-stage Development Section  
of Wangzhuang Industry Area, Wuxi High &  
New Technology Industry Development Zone.

TEL: 0086-510-85205041  
FAX: 0086-510-85203796  
E-MAIL: [kipor@kipor.com](mailto:kipor@kipor.com)



## DIESEL GENERATOR

### SINGLE-PHASE:

KDE2200X/E/C  
KDE2500E  
KDE3500X/E/C/T  
KDE5000X/E/T  
KDE6500X/E/T  
KDE6700T/TA  
KDA6700TA/TAO

### THREE-PHASE:

KDE6500X3/E3/T3  
KDE6700T3/TA3  
KDA6700TA3/TAO3





**EC Declaration of Conformity**  
**According to EU Machinery-Directive 98/37/EC**

**We, Wuxi Kipor Power Co., Ltd.** ( Add: Beside Jingyi Rd, Third-stage Development Section of Wangzhuang Industry Area, Wuxi High & New Technology Industry Development Zone.)

declare under our sole responsibility that the product diesel generator set: KDE2200X, KDE2200E, KDE2200C, KDE2500E, KDE3500X, KDE3500E, KDE3500C, KDE3500T, KDE5000X, KDE5000E, KDE5000T, KDE6500X, KDE6500E, KDE6500T, KDE6700T, KDE6700TA, KDA6700TA, KDA6700TAO, KDE6500X3, KDE6500E3, KDE6500T3, KDE6700T3, KDE6700TA3, KDA6700TA3, KDA6700TAO3, to which this declaration relates correspond to the relevant basic safety and health requirements of Directive:

- 98/37/EC (Machinery-Directive),
- 2006/95/EC (LVD-Directive),
- 89/336/EC (EMC-Directive), and
- 2000/14/EC (noise directive) incl. modifications.

*For the relevant implementation of the safety and health requirements mentioned in the Directives, the following standards and/or technical specification(s) have been respected:*

EN 55012:2002/+A1:2005,  
EN 12601: 2001,  
EN ISO 3744, ISO 11094.

<i>measured sound power level</i>	<b>94.0dB(A)</b>
<i>guaranteed sound power level</i>	<b>95.0dB(A)</b>

*Conformity assessment method to annex VI/Directive 2000/14/EC*

*Maintenance of technical documentation:*

**Wuxi Kipor Power Co., Ltd.**

Signature: Shuoming Huang

Name: Shuoming Huang

Quality Guarentee Manager

## PREFACE

Thank you for purchasing diesel generators.

This operation manual will tell you how to install, use and maintain generator set correctly.

Please read this manual before using the generating set to ensure the proper operation.

Follow the instructions to keep your generating set in the best working condition and extend the life of it. If you have any comments or problem, please contact with our sales company or the authorized agent.

This manual deals with the general items of the diesel generating set. However, the manual may vary with the development of the products in the future.

Please give special attentions to warnings and cautions.



Failure to properly follow these precautions can result in property damage, serious injury or DEATH!



Indicates that the serious personal injury or equipment damage will result if the instructions are not followed.

Diesel generating set will meet your requirement if you operate it according to the manual instruction. Otherwise serious personal injury and equipment damage will result.

So, reconfirms that you must to read and understand this manual before operating the generating set.

### **ATTENTION**

1. Don't connect the generator to other power supplies. Such as main-supply of power company. In some special cases, please connect the stand-by power to the electrical system by professional electrician who must know the difference between public supply and generator circuit.
2. Laymen especially the children can not realize the danger, they should keep away from the generator.
3. Please wear suitable clothes and safety protective coverall.
4. The key of door lock and electric door accessories for meter door and maintenance door of silent unit should be well kept by operators. Please lock all the doors of generator tightly to prevent laymen to operate (the children can not realize the danger).



## WARNING:

### 1. TO PREVENT THE FIRE

Never add fuel to the fuel tank while the engine is running.

Wipe off the overflowed fuel oil with a clean cloth. Keep explosives and other flammable products away from the generating set.

- To prevent the fire and to provide adequate ventilation, keep the generating set at least one meter away from buildings and other equipment during operation.
- Operate the generating set on a level surface.
- Do not put the generating set indoors while the engine is hot.
- Set up extinguisher and first-aid kit in working field.

### 2. TO PREVENT FROM INHALING THE EXHAUST

Exhaust gas contains poisonous carbon monoxide, which is harmful to the health. Never use the generating set at the confined places or poor ventilated locations. If it's necessary to run the generating set indoors, be sure to provide the adequate ventilation.

Please note the warning labels on the generator.

### 3. BE CARE NOT TO BE SCALDED

The muffler and the engine body are very hot while the engine is running or just after running, do not touch these parts to prevent from being scalded.

### 4. ELECTRIC SHOCKS, SHORT CIRCUITS

To avoid electric shocks or short circuits, do not touch the generating set when your hands are wet. This generating set is not waterproof, so it should not be used in a place exposed to rain snow or water sprays. Use of the generating set in a wet place can cause short circuits and electric shocks during operation.

- The generating set should be grounded to prevent electrical shocks from faulty appliances. Connect a length of heavy wires between the generating set's ground terminal and an external ground source.
- Do not hook up tools or other apparatus to generating set rator before it has been started. If equipment is attached, generator starting may cause sudden movements of the equipment and result in injuries and accidents. Be sure to disconnect any apparatus from the generating set or prior to starting.

## 2. Modified coefficient table of ambient condition power

The conditions of generator rated output:

Altitude: 0 m      Ambient temperature: 25°C      Relative humidity: 30%

Ambient modified coefficient: C (Relative humidity 30%)

Altitude (m)	Ambient temperature (°C)				
	25	30	35	40	45
0	1	0.98	0.96	0.93	0.90
500	0.93	0.91	0.89	0.87	0.84
1000	0.87	0.85	0.82	0.80	0.78
2000	0.75	0.73	0.71	0.69	0.66
3000	0.64	0.62	0.6	0.58	0.56
4000	0.54	0.52	0.5	0.48	0.46

Note: When the relative humidity is 60%, the modified coefficient is C-0.01

When the relative humidity is 80%, the modified coefficient is C-0.02

When the relative humidity is 90%, the modified coefficient is C-0.03

When the relative humidity is 100%, the modified coefficient is C-0.04

Counting example:

When the rated power of generator is  $P_N = 5\text{KW}$ , altitude is 1000m, ambient temperature is 35°C, relative humidity is 80%, the rated power of generator is:

$$P = P_N \times (C - 0.02) = 5 \times (0.82 - 0.02) = 4\text{KW}$$

## 13. APPENDIX

### 1. The choice of the electric cable

The choice of the electric cable depends on the allowable current of the cable and the distance between the load and the generator. And the cable section should be big enough.

If the current in the cable is bigger than the allowable current, it will become over hot and the cable will be burnt. If the cable is long and thin, the input voltage of the electric appliance will be not enough, causing that the generator doesn't start. In the following formula, you can calculate the value of the potential "e".

$$\text{Potential (v)} = \frac{1}{58} \times \frac{\text{Length}}{\text{Section area}} \times \text{Current (A)} \times \sqrt{3}$$

The relations among of the allowable current, and length, section of the Insulating cable (single core, multi-core) are as follow:

(Presume that the use voltage is 220V and the potential is below 10V.

**Ambient temperature: 25°C**

No.	Copper cables model	Single core Current capacity (25 °C)(A)		Voltage Drop mv/M	Three cores Current capacity (25 °C)(A)		Voltage Drop mv/M	Four cores Current capacity (25 °C)(A)		Voltage Drop mv/M
		VV22	YJV22		VV22	YJV22		VV22	YJV22	
1	1.5mm <sup>2</sup>	20	25	30.86	13	18	30.86	13	13	20
2	2.5mm <sup>2</sup>	28	35	18.9	18	22	18.9	18	30	28
3	4mm <sup>2</sup>	38	50	11.76	24	32	11.76	25	32	38
4	6mm <sup>2</sup>	48	60	7.86	32	41	7.86	33	42	48
5	10mm <sup>2</sup>	65	85	4.67	45	55	4.67	47	56	65
6	16mm <sup>2</sup>	88	110	2.95	61	75	2.6	65	80	88
7	25mm <sup>2</sup>	113	157	1.87	85	105	1.6	86	108	113
8	35mm <sup>2</sup>	142	192	1.35	105	130	1.2	108	130	142
9	50mm <sup>2</sup>	171	232	1.01	124	155	0.87	137	165	171
10	70mm <sup>2</sup>	218	294	0.71	160	205	0.61	176	220	218
11	95mm <sup>2</sup>	265	355	0.52	201	248	0.45	217	265	265
12	120mm <sup>2</sup>	305	410	0.43	235	292	0.36	253	310	305
13	150mm <sup>2</sup>	355	478	0.36	275	343	0.3	290	360	355
14	185mm <sup>2</sup>	410	550	0.3	323	400	0.25	333	415	410
15	240mm <sup>2</sup>	490	660	0.25	381	480	0.21	400	495	490

**Note:** The variation of temperature and the laying of cables will influence the current capacity of cables, the table above is just used for reference.

### CAUTION

- Most appliance motors require more than their rated wattage for start-up.
- Do not exceed the specified current limit of any socket.
- Do not connect the generating set to a household circuit. This could cause damage to the generating set and to electrical appliances in the house.

### 5. BATTERY USAGE

The battery of open frame generator set is optional, users should choose and buy suitable battery before operation.

The battery of silent generator set adopts advanced technique without maintenance, users need not fill water and add electrolyte.

Observe the status displays of battery:

Blue: the battery is in good condition

White: the electricity is not enough, need to charge.

Red: the electrolyte is not enough, need to change.

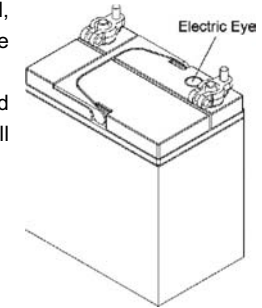

#### Battery usage:

Shut down the power after removing the battery cathodal wire when checking and maintaining generator. Connect battery anode then cathode.

Stop charge quickly after the battery is fully charged.

When the battery is too hot in charging, recharge after stopping for a while.

6.The installation and maintenance of generator should be operated professional maintainer.

7. Restrict application of generator in high-hazard risk to causing fire area.

8. Don't pour waste oil into the sewer or the river to prevent environment pollution. The exhaust oil from generator must be stored in container. To deal with bad matter, such as fuel, oil cooling water, solvent, filter and battery, according to the law.

9.The exhaust gas and fuel of generator are poisonous. Please operate carefully.

# CONTENTS

1. Main Technical Specifications and Data .....	1
2. Configuration.....	3
3. Preparation for Starting .....	5
4. Start the Generating Set .....	8
5. Operate the Generating Set`.....	13
6. Load .....	14
7. Stop the Generating Set .....	18
8. Periodic Checks and Service .....	19
9. Long-term Storage .....	22
10. Troubleshooting and Remedy .....	23
11. Intelligent panel functions .....	24
12. Electric diagram.....	25
13. Appendix .....	40

12.15 KDA6700TA Electric diagram

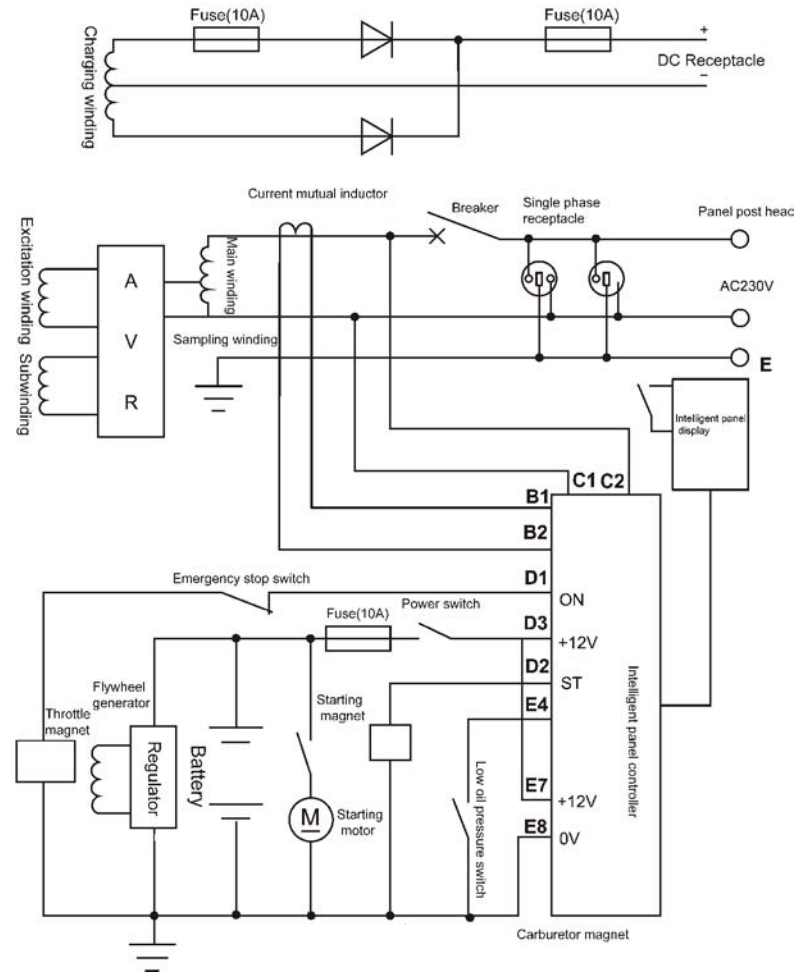



12.14 KDE5000T/KDE6500T Electric diagram

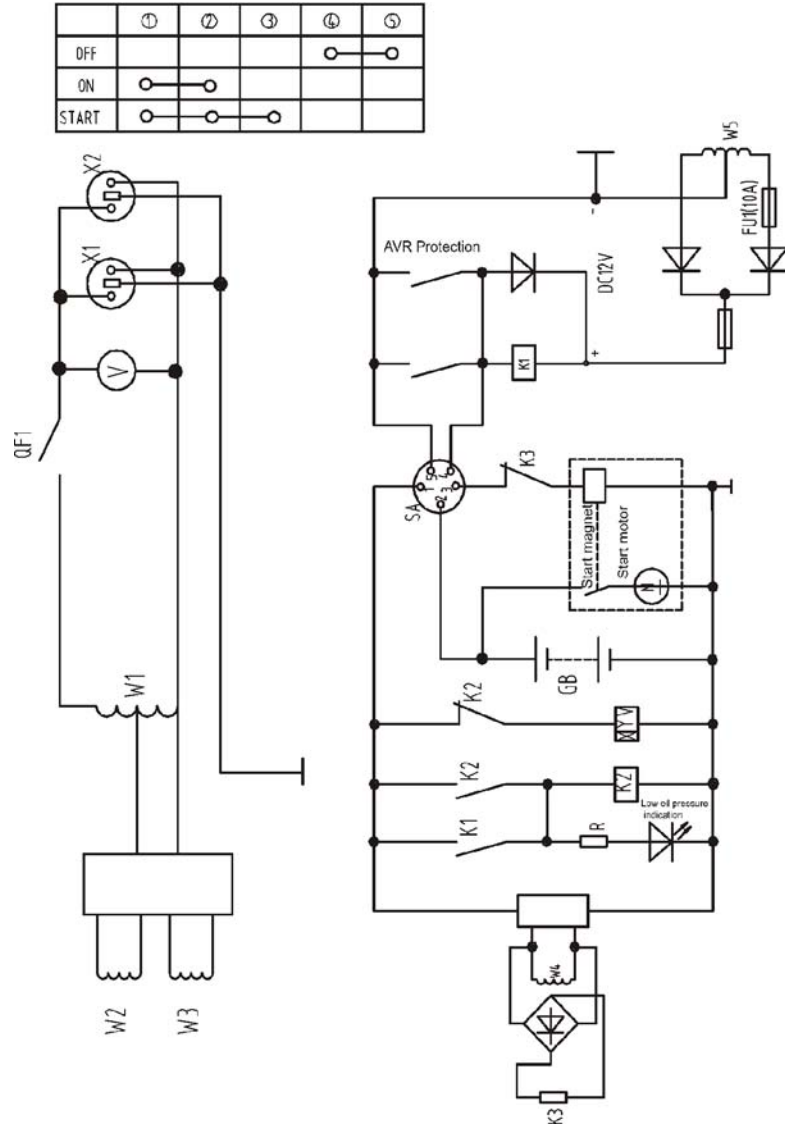

## 1. MAIN TECHNICAL SPECIFICATIONS AND DATA

### 1.1 Main Technical Specifications and Data

Item	KDE2200X KDE2200E KDE2200C KDE2500E		KDE3500X KDE3500E KDE3500C KDE3500T		KDE5000X KDE5000E KDE5000T		KDE6500X/E3 KDE6500T3 KDE6700T3/TA3 KDA6700TA3 KDA6700TAO3	
	Rated frequency (HZ)	50	60	50	60	50	60	50
Rated power (kVA)	1.7	2	2.8	3.3	4.2	5	4.5	5.5
Rated voltage(V)	115/230	120/240	115/230	120/240	115/230	120/240	115/230	240/120
Rated current (A)	14.8/7.4	16.7/8.3	24.3/12.2	27.5/13.8	36.5/18.3	41.7/20.8	39.1/19.6	20.8/41.7
Rated revolution speed (r/min)	3000	3600	3000	3600	3000	3600	3000	3600
Phase No.	Single phase							
Power factor (cos φ)	1							
Excitation mode	Controlled silicon self excitation constant voltage							
DC output	12V/8.3A							
Coupling method	Transmission rigid connection							
Low oil alarm system	With							
Fuel oil tank capacity (L)	13.5	X/E:13.5	T:15	X/E:13.5	T:15	E:13.5	T/TA:15	E:13.5 T3/TA3: 15
Net weight (kg)	C/X:53	E:60	C/X:65	E:70	T:140	X/E:70	T:158	X:95 E:100 6500T:158 6700T/TA:170
Overall dimensions (L×W×H)(mm)	C: 595×410×515 X/E: 640×480×530	C: 630×445×530 X/E: 655×480×530 T: 830×532×740	X/E:720×492×650 T:830×532×740	X/E:720×492×650 6500T:912×532×740 6700T/TA/TAO: 915×547×742	X:85 E:100 6500T:3165 6700T:3/TA3:177	X:85 E:100 6500T:3165 6700T:3/TA3:177	X:85 E:100 6500T:3165 6700T:3/TA3:177	X:85 E:100 6500T:3165 6700T:3/TA3:177

Generating Set

Model	KDE2200X KDE2200E KDE2200C KDE2500E	KDE3500X KDE3500E KDE3500C KDE3500T	KDE5000X KDE5000E KDE5000T	KDE6500X/E KDE6500T KDE6700T3/TA3 KDA6700TA3 KDA6700TAO3
Item				
Model	KM170F	C/X/E:KM178FG T:KM178FGET	C/X/E:KM186FG T:KM186FGE	KM186FAG
Type	4-stroke, single-cylinder, air-cooled, direct injection diesel engine			
Bore x stroke (mm)	70 × 55	78 × 62	86 × 70	86 × 72
Displacement (L)	0.211	0.296	0.406	0.418
Lube oil capacity (L)	0.75	1.1	1.65	1.65
Rated power (kW)	2.5/3000	2.8/3600	4.0/3600	5.7/3000 6.3/3600
Fuel type	Diesel 0# (summer) -10# (winter) -35# (chilling)			
Lube oil brand	CD grade or 10W-30, 15W-40			
Starting system	C/X/E: Recoil starter E/T/TA/E3/T3/TA3: Electric starter			
Structure mode	C/X/E/E3: Open frame type T/TA/T3/TA3: Silence type			
Model	KDE6500X3/E3 KDE6500T3 KDE6700T3/TA3 KDA6700TA3 KDA6700TAO3			
Item				
Model	KM170F	C/X/E:KM178FG T:KM178FGET	C/X/E:KM186FG T:KM186FGE	KM186FAG
Type	4-stroke, single-cylinder, air-cooled, direct injection diesel engine			
Bore x stroke (mm)	70 × 55	78 × 62	86 × 70	86 × 72
Displacement (L)	0.211	0.296	0.406	0.418
Lube oil capacity (L)	0.75	1.1	1.65	1.65
Rated power (kW)	2.5/3000	2.8/3600	4.0/3600	5.7/3000 6.3/3600
Fuel type	Diesel 0# (summer) -10# (winter) -35# (chilling)			
Lube oil brand	CD grade or 10W-30, 15W-40			
Starting system	C/X/E: Recoil starter E/T/TA/E3/T3/TA3: Electric starter			
Structure mode	C/X/E/E3: Open frame type T/TA/T3/TA3: Silence type			

**Instruction:** the noise list indicates the noise emission level while not the safe working noise level. Although the noise emission level is related to the sound exposure level, it is not the judging standard for whether applying noise protection. Factors affect the practical noise level include: the ambient condition and other noise source, such as the quantity of working machine or the working hours in noisy condition. Furthermore, the sound exposure level varies among different countries.

**Note:** A is intelligent control panel

12.13 KDE2200E/KDE2500E/KDE3500E/KDE5000E Electric diagram (double voltage output)

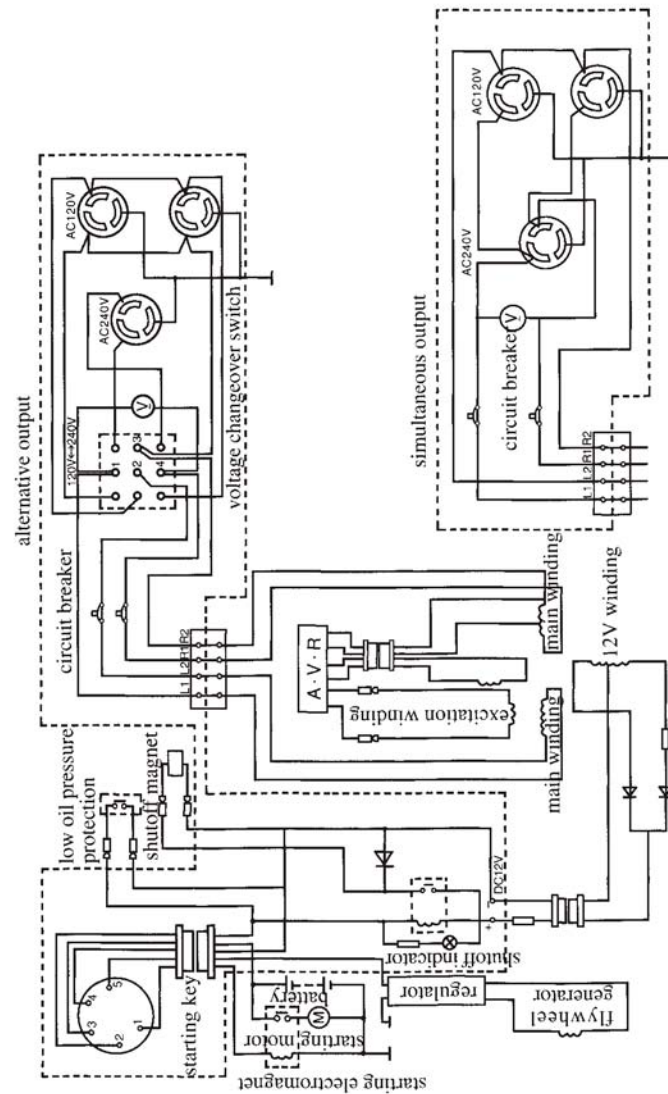

12.12 KDE2200E/KDE2500E/KDE3500E/KDE5000E Electric diagram  
(single voltage output)

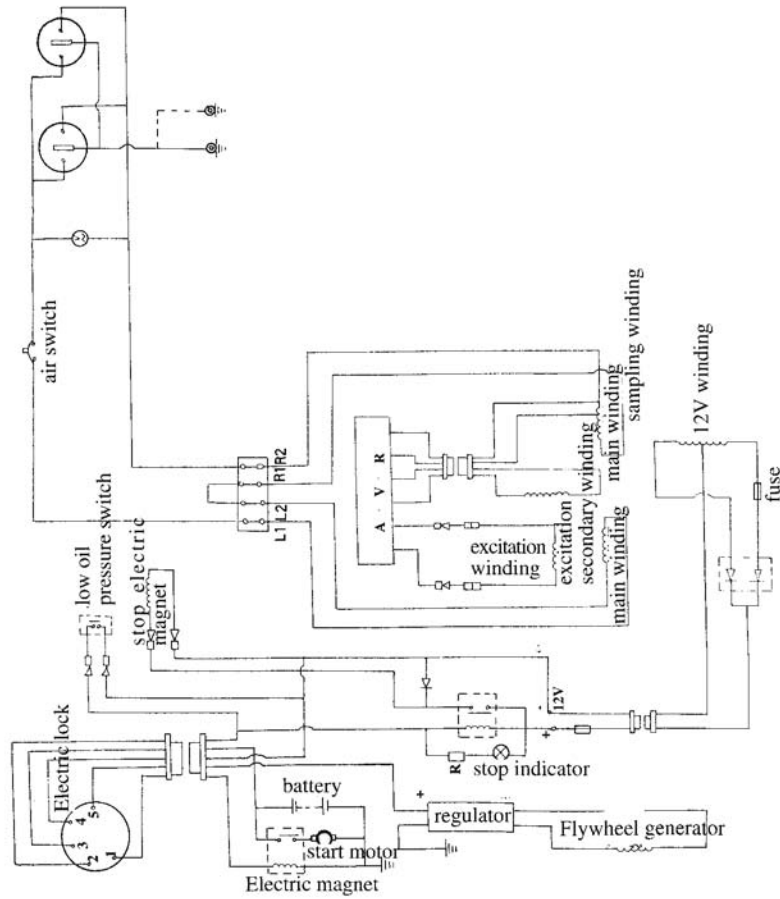

## 2. CONFIGURATION

a .Parts names(KDE SERIES E type figs)

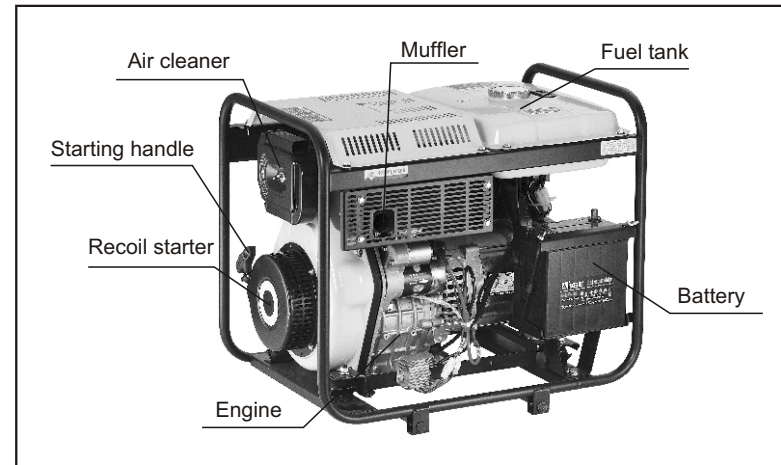
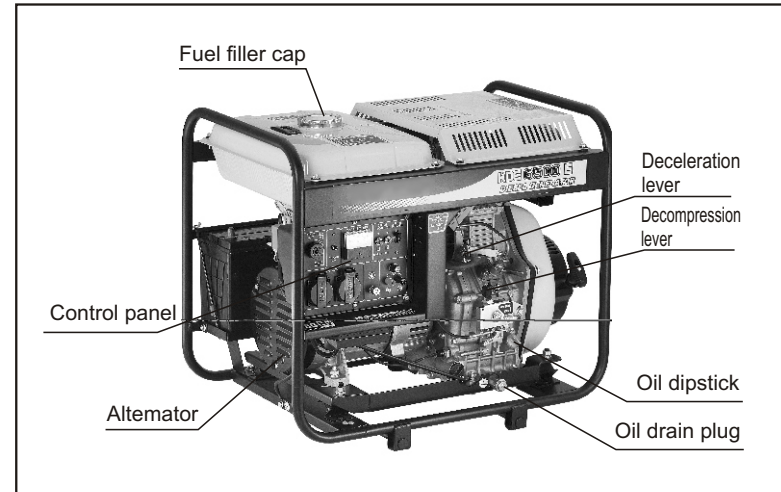

b. Parts names (KDE series T/T3/TA/TA3 type figs)

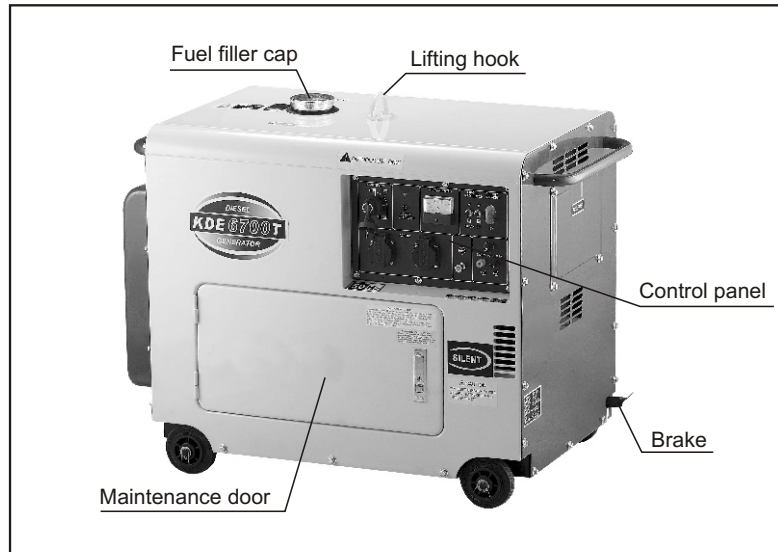

12.11 KDE2200X/KDE5000X/KDE6500X Electric diagram (double voltage output)

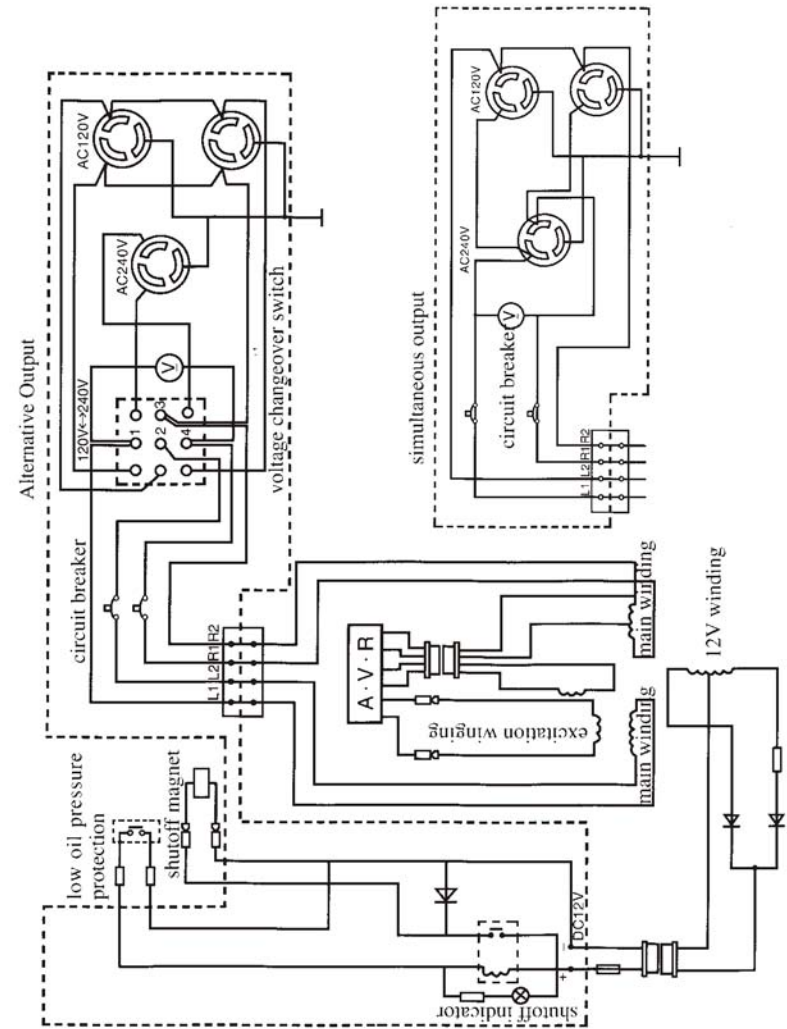

12.10 KDE2200X/KDE5000X/KDE6500X Electric diagram (single voltage output)

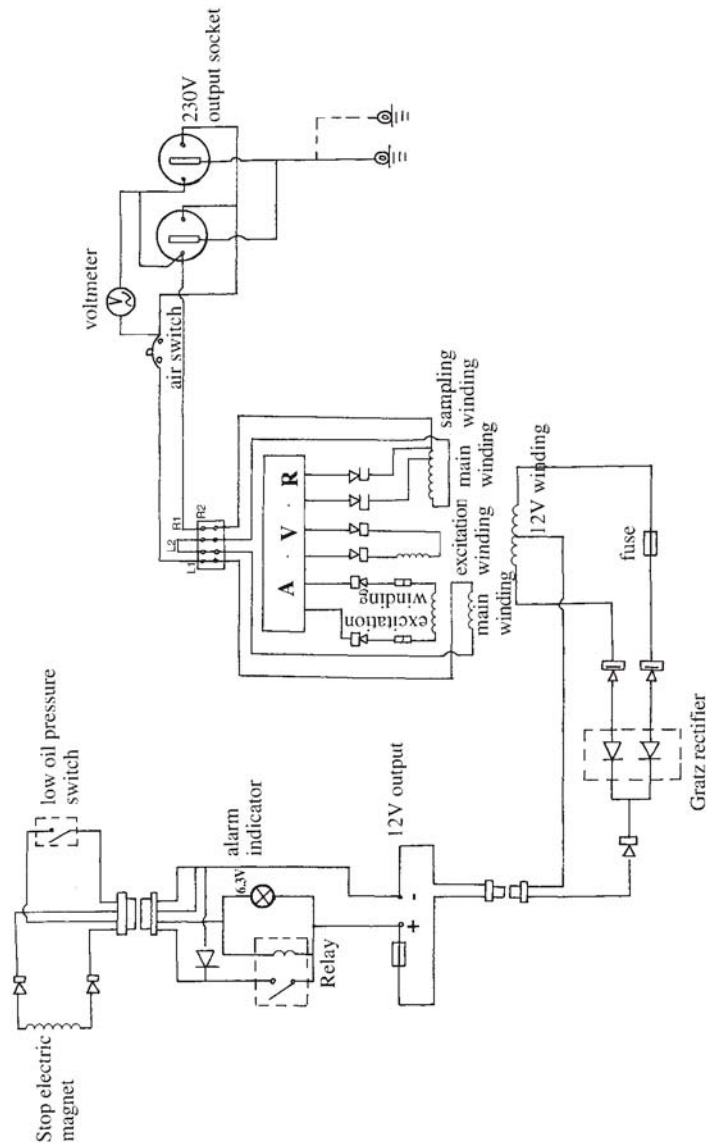

### 3. PREPARATION FOR STARTING

#### 3.1 Selection and handling of the fuel oil

- Selection of fuel oil  
Only use the light diesel, which is most suitable for the engine.
- Keep dust and water out of the fuel  
When filling the fuel tank from drums, make sure that no dust or water is mixed in the fuel. Otherwise the serious fuel injection pump and nozzle problems will result.
- Do not overfill  
Overfilling is very dangerous. Do not fill the tank beyond the top of the red plug inside the fuel oil filter.

#### ⚠ WARNING

- Refuel in a well-ventilated area with the engine stopped.
- Do not smoke or allow flames or sparks in the area where the engine is refueled or where the fuel oil stored.
- Do not overfill the tank, make sure the filler cap is securely closed after refueling.
- Be careful not to spill fuel when refueling. If any fuel is spilled, make sure the area is dry before starting the engine.

#### 3.2 Check and refill the engine oil

#### ⚠ WARNING

- Always check the engine oil level with the generating set on a level surface before starting and refill if necessary.
- The engine may be damaged if operated with insufficient engine oil, it is also dangerous to refill too much engine oil as sudden increase in engine speed may be caused by its combustion.

**⚠ CAUTION:**

KDE series generating set are equipped with low oil warning system. This system will stop the engine automatically when the oil level falls below the lower level. This prevents accidents such as bearing seizures, etc.

■ Select the most applicable engine oil

It is very important to select the applicable engine oil for keep up the performance and life of the generating set. If inferior engine oil is used, or if your engine oil is not replaced periodically, the risk of piston seizure, piston ring sticking and accelerated wear of the cylinder liner, bearing and other moving components increases significantly. So the generating set life will be shortened. recommends CC/CD oil classified by API. Choose the applicable viscosity oil according to the local ambient temperature.

**3.3 Service the air cleaner**

1. Screw off the wing nut, remove the air cleaner cover and take out the element.

**⚠ CAUTION:**

- Do not wash the element with detergent.
- Replace the element when its output decrease or a bad exhaust color is noticed.
- Never run the generating set without the element, otherwise the rapid engine wear will result.

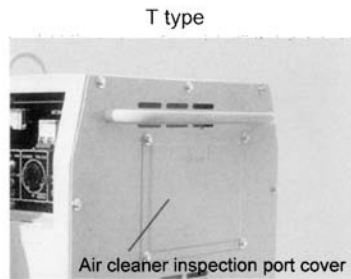
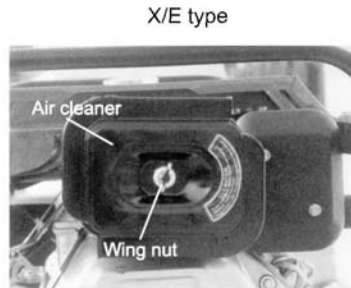

12.9 KDE2200C/KDE3500C Electric diagram

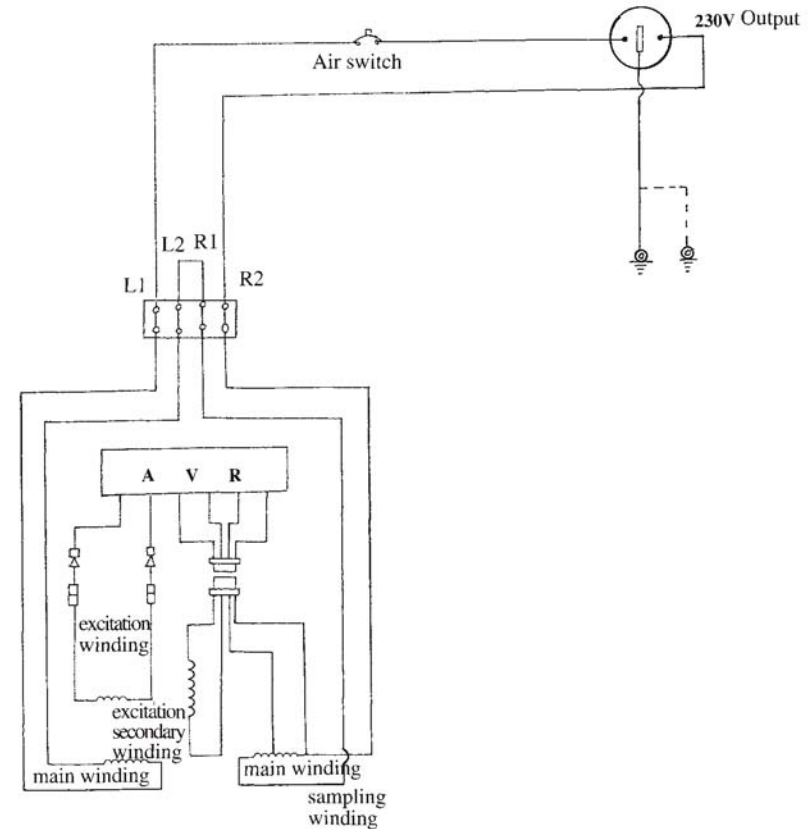

12.8 KDE6700TA3 Electric diagram(2)

Electric Start Key ON/OFF Table

	①	②	③	④	⑤
OFF				○	○
ON	○	○			
START	○	○	○		

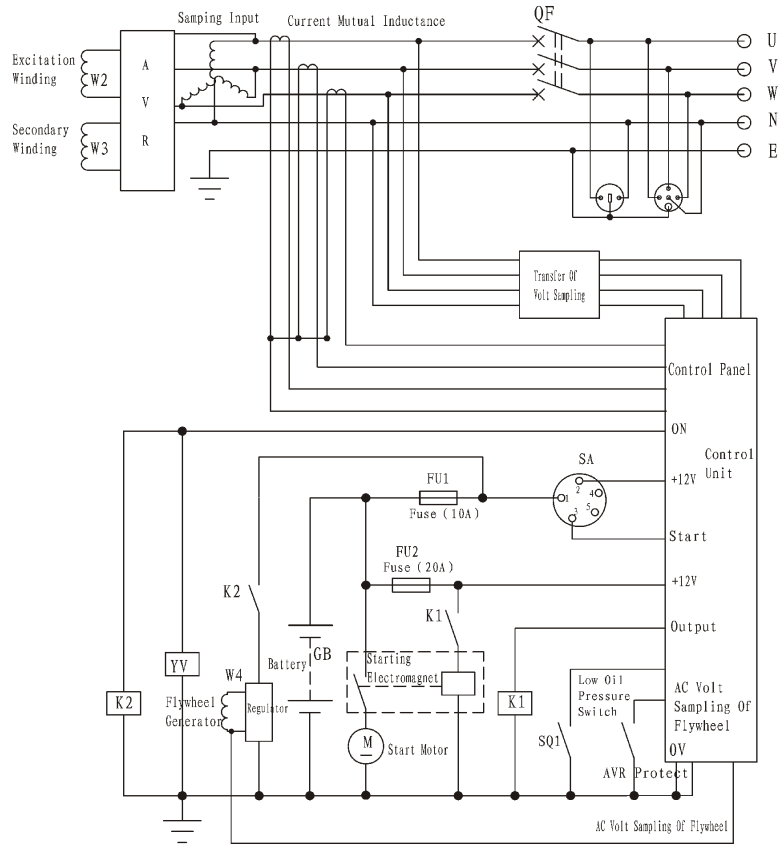

2. Reattach the air cleaner cover and screw on the wing nut.

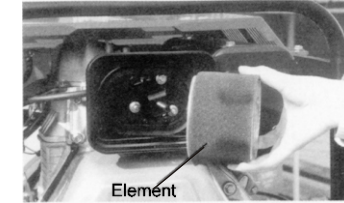

3.4 Check the generating set

1. Turn off the main switch and any other loads.

**⚠ WARNING:**

- Be sure to turn off the main switch before starting.
- The generating set should be earthed to prevent electric shocks.

**⚠ WARNING:**

- The generating set should be earthed to prevent electric shocks.

**⚠ CAUTION**

- The main switch should always be kept in the "ON" position during operation.
- Before starting the engine, be sure to turn the switches of the working instrument (lighting apparatus, motor, etc.) to their "OFF" position. If the switches are not "OFF", the sudden application of load when the engine is started could be very dangerous.

3.5 Break-in period operation

The first 20hrs are the break-in period of the engine, the operator must obey to following items:

- Warm up the engine 5 minutes after the initial starting. Run the engine at low speed and zero load before the engine becomes warm.

- Avoid applying any heavy loads during the break-in period. recommends to run the engine at 3000r/min with 50% load in break-in period. Replace the engine oil on time.
- Replace the engine oil while the engine is warm after 20-hours -running, the old engine oil will be drained out completely.

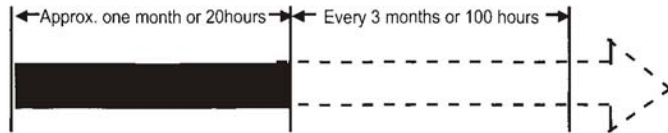

#### 4. START THE GENERATING SET

**⚠ WARNING**

■ Do not hook up tools or other apparatus to the generating set before starting.

##### 4-1 Recoil starting

Start the engine according to the following procedures:

1. Open the fuel cock.

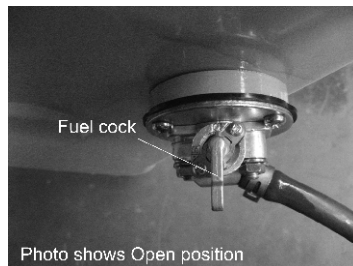

#### 12.8 KDE6700TA3 Electric diagram(1)

ON-OFF Table of Electric Starter Key

	①	②	③	④	⑤
OFF				○	○
ON	○	○			
START	○	○	○		

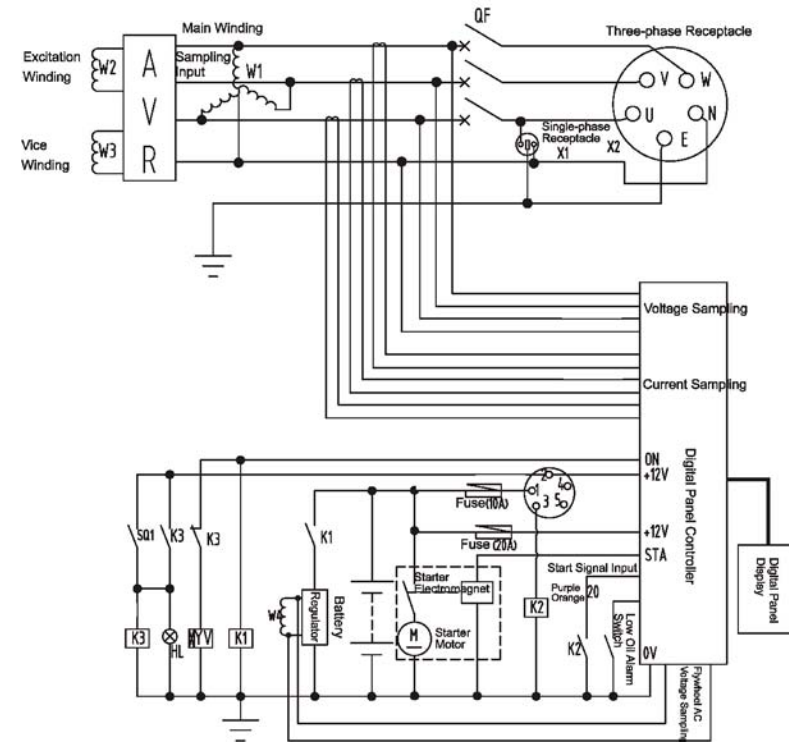



12.7 KDE6700TA Electric diagram(2)

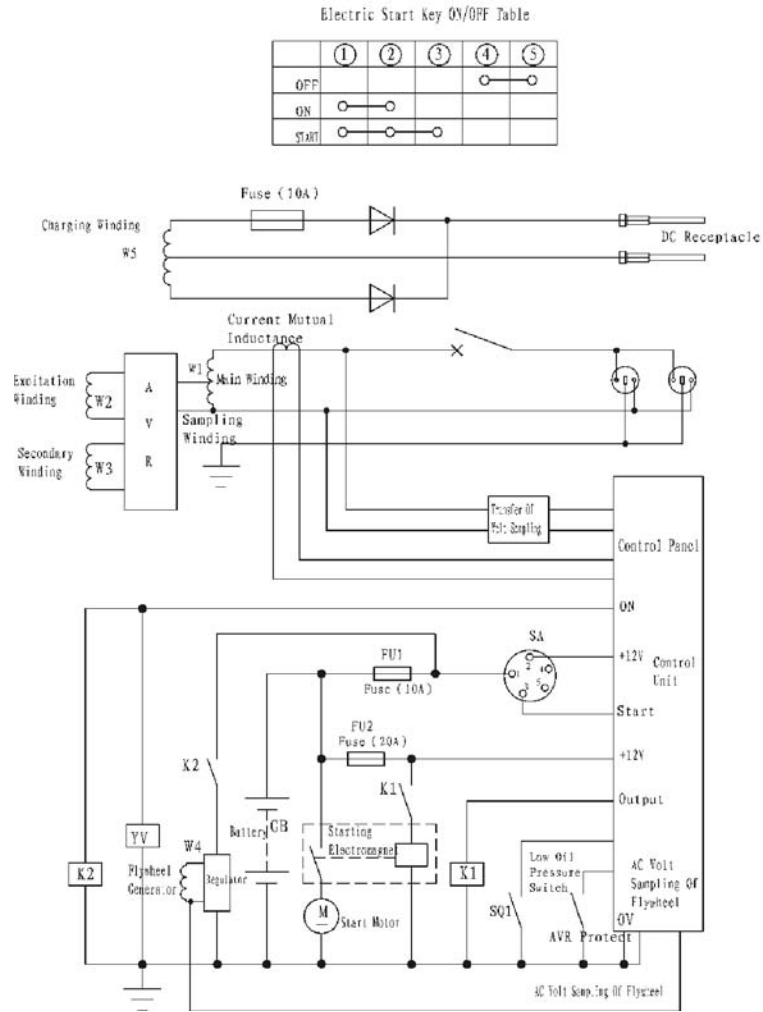

- Set the engine speed lever at the RUN position.

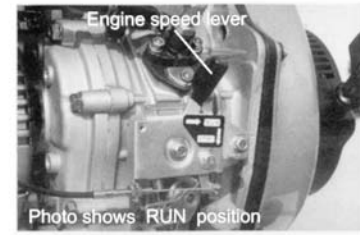

- Pull out the recoil starter handle.

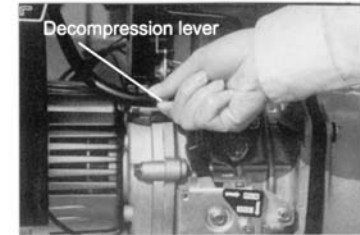

- Pull out the handle until you feel the resistance, then return it back to the initial position.
- Press down the decompression lever. It will return automatically when the recoil starter is pulled.
- Pull out the recoil starter handle briskly with both hands.

**⚠ CAUTION**

- Do not allow the handle grip to snap back against the engine. Return it gently to prevent damage to the starter.
- When the engine is difficult to start in cold weather, remove the screw plug from the cylinder head cover and add 2cc engine oil.

**⚠ CAUTION**

- Always screw on the screw plug on the cylinder head cover except filling, to prevent the rain and dirty flowing into the engine body. Otherwise the quick wear of the internal parts and other serious problems will result.

Recoil starting

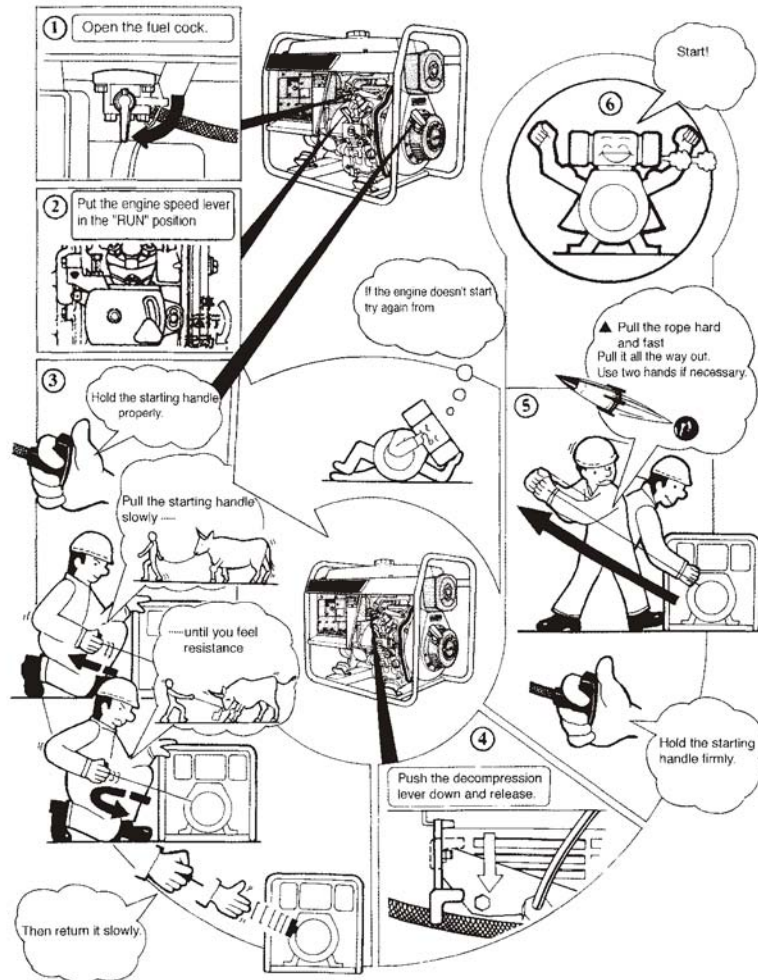

12.7 KDE6700TA Electric diagram(1)

ON-OFF Table of Electric Starter Key

	①	②	③	④	⑤
OFF				○	○
ON	○	○			
START	○	○	○		

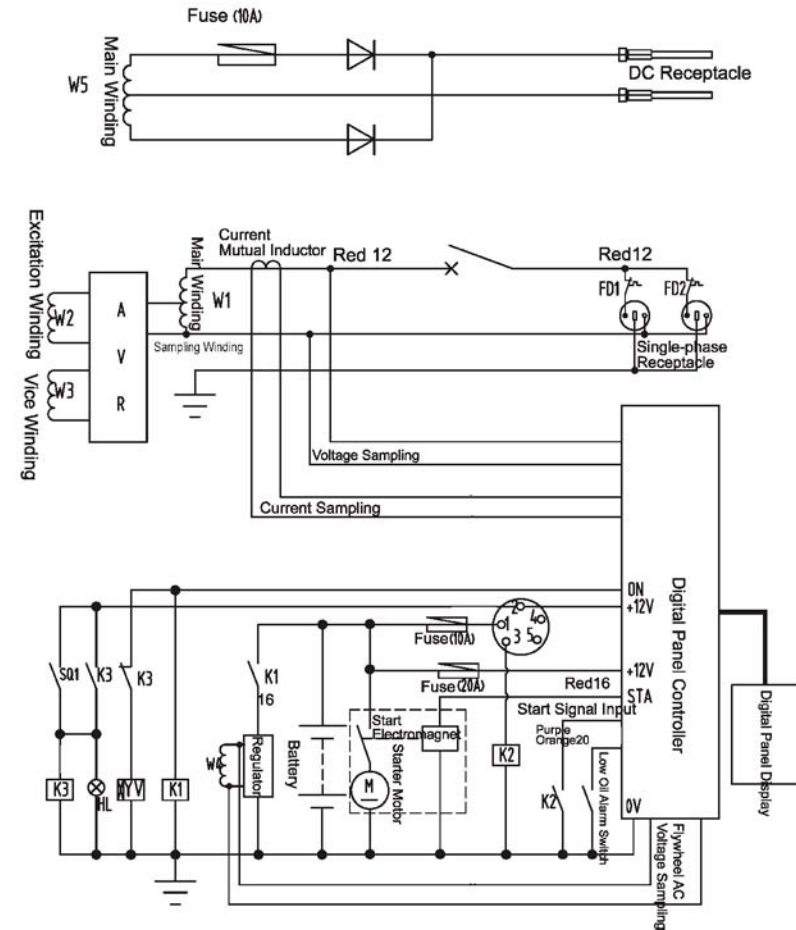

12.6 KDE6700T Electric diagram

ON-OFF Table of Electric Starter Key

	①	②	③	④	⑤
OFF					○—○
ON	○—○				
START	○—○	○—○			

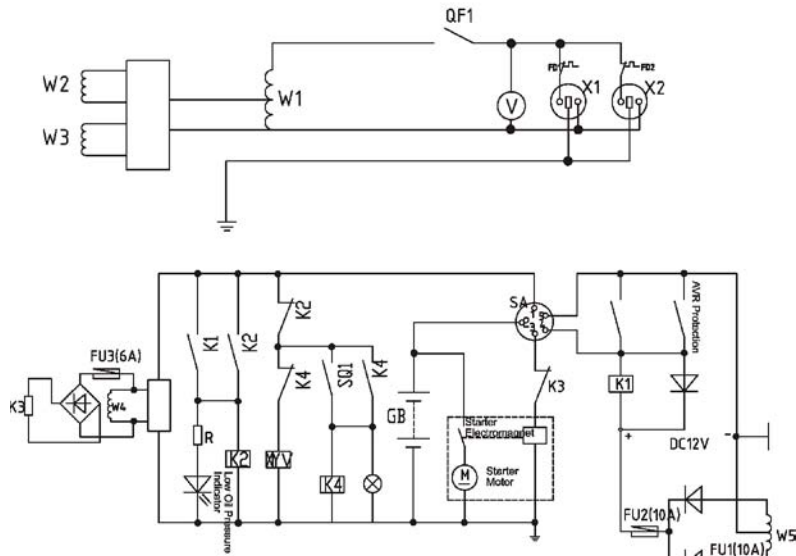

Recoil starting

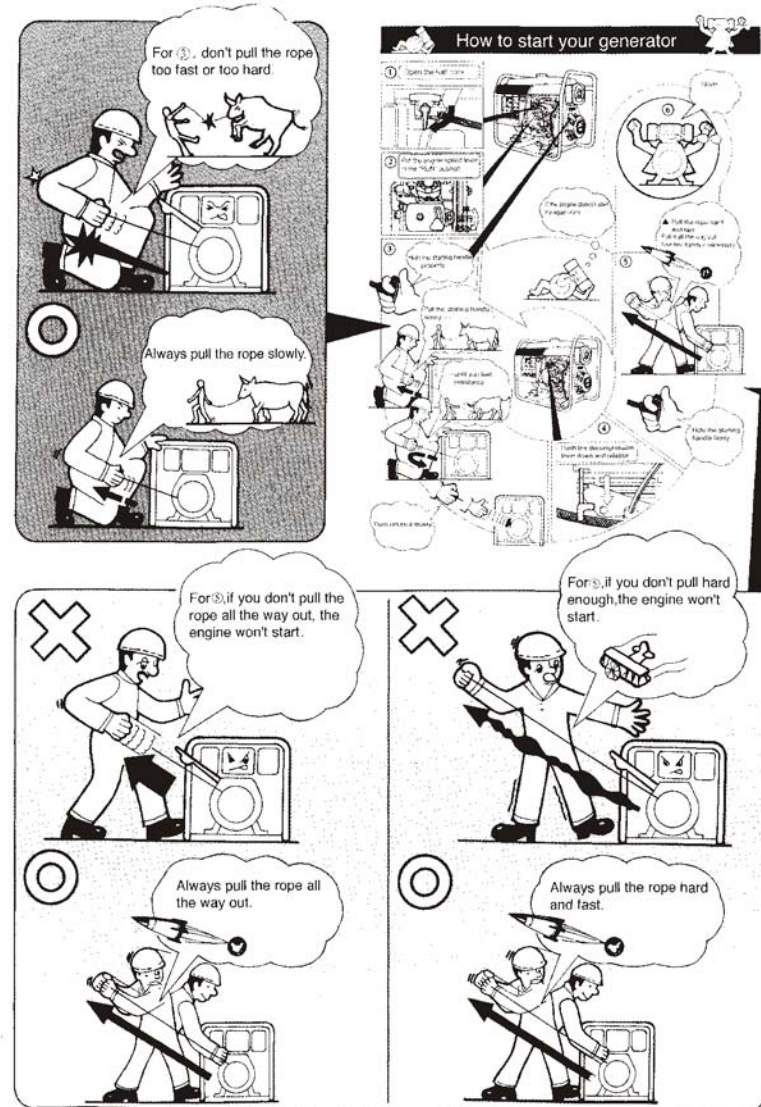

## 4.2 Electric starting

1. Starting (The preparations for electric starting are the same as for the recoil starting.)

- Open the fuel cock.
- Set the engine speed lever at "RUN" position.

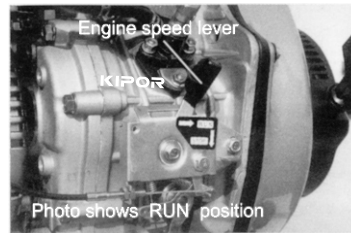

Photo shows RUN position

- Turn the starting key clockwise to "START" position. Remove your hand from the key as soon as the engine starts. If the starting motor does not start after 10 seconds, wait 15 seconds before starting it again.



### ⚠ CAUTION

- Run the starting motor for long time will cost the battery power greatly even burn out the motor.
- Always leave the starting key at "ON" position while the engine is running.

## 2. Battery

Check the battery voltage before starting generator set every time.

## 12.5 KDE6500T3/KDE6700T3 Electric diagram

ON-OFF Table of Electric Starter Key

	①	②	③	④	⑤
OFF				○—○	
ON	○—○				
START	○—○	○—○	○—○		

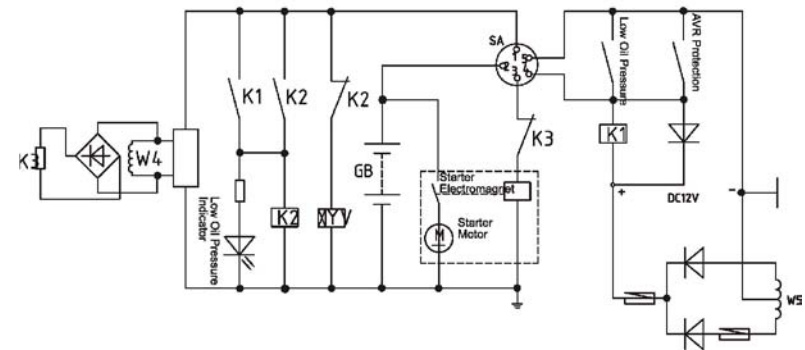
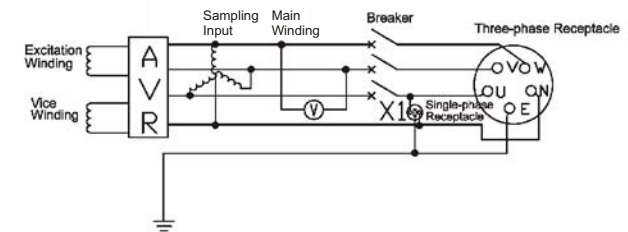

12.4 KDE3500T Electric diagram

	①	②	③	④	⑤
OFF					
ON	○	○			
START	○	○	○		

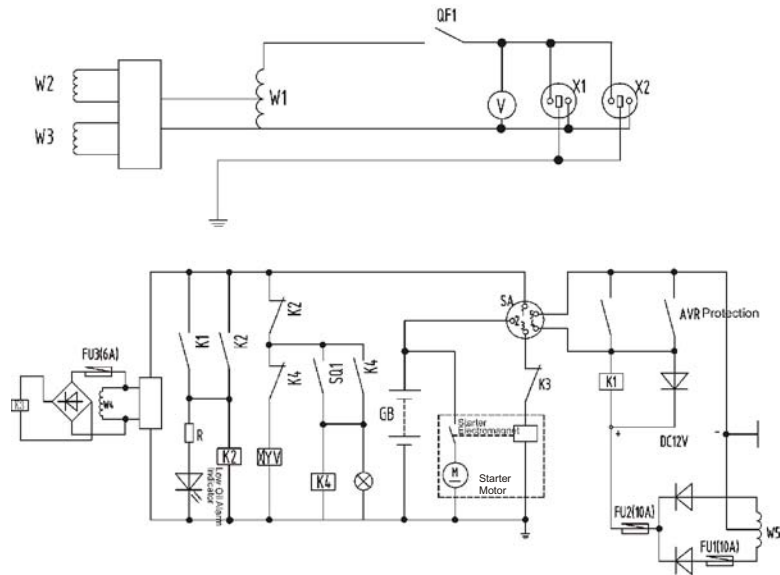

## 5. OPERATE THE GENERATING SET

### 5.1 Operate the generating set

1. Warm up the engine without load three minutes.

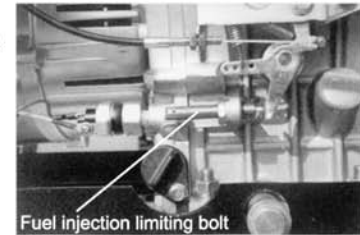

2. Concerning the generating set with Low Oil Warning System, check that the Oil Alarm Lamp is not lit.



### CAUTION

- For the generating set with Low Oil Warning System, the Oil Alarm Lamp will be activated by low oil pressure or engine oil shortage, simultaneously, the engine will stop. The engine will stop immediately if restarted without refilling the engine oil. Check the oil level and refill.
- Do not loosen or readjust either the engine speed limiting bolt or fuel injection limiting bolt, otherwise, the performance will be affected.

### 5.2 Checks during the running

1. Whether there is abnormal sound or vibration;
2. Whether the engine misfires or runs rough;
3. Check the color of the exhaust. (Is it black or too white?)  
If you notice any of the above-mentioned phenomenon happened, stop the engine and find out the fault cause or contact with agent.

**CAUTION**

- If the engine has been running, the muffler will be very hot. Be careful not to touch the muffler.
- Never refill the fuel tank while the engine is running.

**6. LOAD**

**CAUTION**

- Do not start 2 or more machines simultaneously. Start them one by one.
- Do not use floodlights together with other machines.

**6.1 AC application**

1. Be sure to run the generating set at rated speed, otherwise AVR(Automatic Voltage Regulator) will produce the forced excitation. If the running is for a long time under such condition, AVR will be burned out.
2. After switching on the air switch, observe the voltmeter on the panel of the control cabinet, the voltmeter should point to  $230V \pm 5\%(50Hz)$  for single-phase generating set;  $400V \pm 5\%(50Hz)$  for three-phase generating set, then the loading can be carried out.

12.3 KDE6500E3/X3 Electric diagram

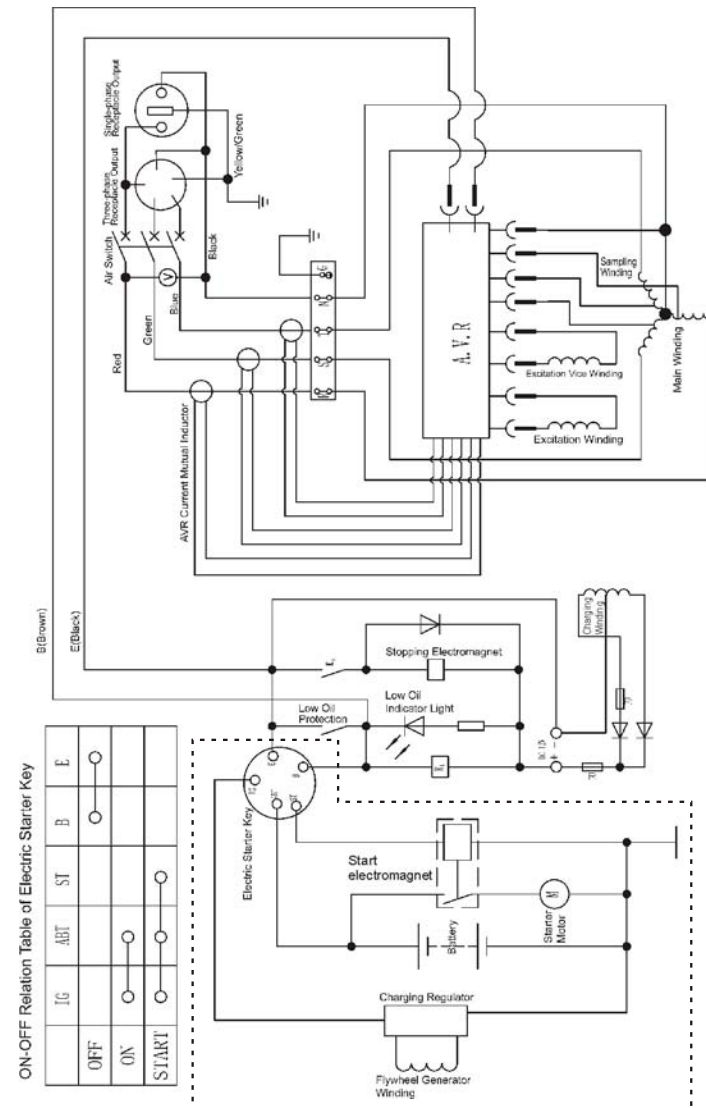

Description: For set X3 type, the components in the two-point-and-line box are not mounted.

## 12.2 KDE6500E Electric diagram

ON-OFF Relation Table of Electric Starter Key

	IG	ABT	ST	B	E
OFF				○	○
ON	○	○			
START	○	○	○		

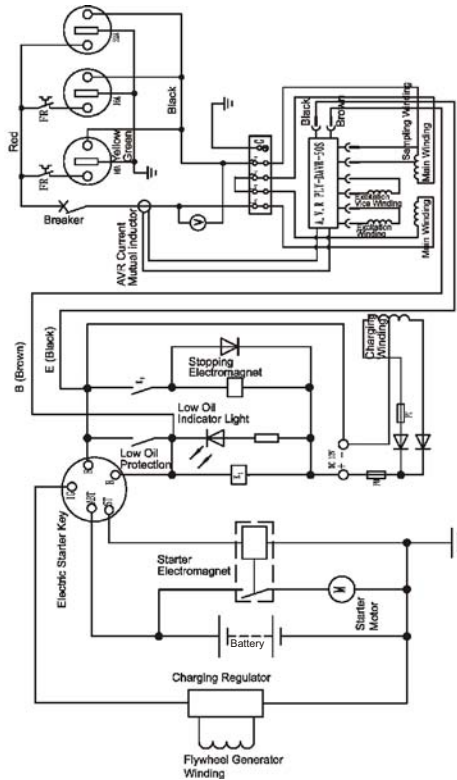

- When the double voltage generating set changes over the voltage, the air switch should be set at "OFF" position. Otherwise the generating set and electric devices will be burned out and damaged.
- Connect the equipment to the generating set in order. For the matter of the motor load, firstly the heavy-duty motor should be connected, then the light-duty motors. If the operation is false, the generating set will lag or stop suddenly. It is necessary to unload the generating set immediately and turn off the main switch and do checks.

### 5. Three-phase generating set

- Balance three phases during the operation. Stop the engine for check if the tolerance exceed 20%.
- The load for each phase must below the rated load as well as the current must less than rated current.
- A,B,C,D(or U, V, W, N) phase arrangement should be from left to right, or clockwise.

Concerning starting the three phase asynchronous motors, first start the high-power motors, then start the low-power motors.



### NOTE

- If overloading of the circuit trips the AC circuit protector, reduce the electrical load on the circuit, and wait a few minutes before resuming operation.

Breaker can prevent the electric shock. If need to replace , please replace one that has equal degree and performance.

Electrical equipment (including electrical lines and plugs connection) could not be defective. By the effect of mechanical stress, make sure to use the rubber sheathed flexible cable or analog (accord with IEC245-4).

Limit length of electric line when using the extension line or distributed network is: less than 60m for cables of 1.5mm<sup>2</sup>, and less than 100m for cables of 2.5mm<sup>2</sup>.

## 6.2 DC application

1. DC terminals are only for charging 12V battery.
2. Set the air switch at "OFF" position while charging. On the 12V output terminals, a charge switch can be connected so the switch can be used for on-and-off purpose.
3. Concerning the automatic type battery with the leads, be sure to disconnect the negative leads of the battery while charging.

### ⚠ CAUTION

- Connect the positive and negative poles of the battery with the positive and negative poles of DC terminals separately. Do not confuse them, otherwise the battery and generating set will burn out.
- Do not connect the positive pole of the battery with its negative pole, otherwise the battery damage will result.
- Do not connect the positive pole of the DC terminal with its negative pole, otherwise the generating set damage will result.
- When a large capacity battery is charged, excessive current flows, the fuse for the direct current will burn out.
- Do not start the generating set while it is still connected with the battery.
- Do not use DC12V and AC at the same time.

### ⚠ CAUTION

- To prevent from creating a spark near the battery, always connect the charging cables to the battery first and only then to the generating set. When disconnecting, you should disconnect the cables at the generating set first.
- Charge the battery at a well-ventilated place.
- Before charging, remove the cap from each cell of the battery.
- Stop charging if the electrolyte temperature exceed 45°C

## 12. ELECTRIC DIAGRAM

### 12.1 KDE3500X Electric diagram

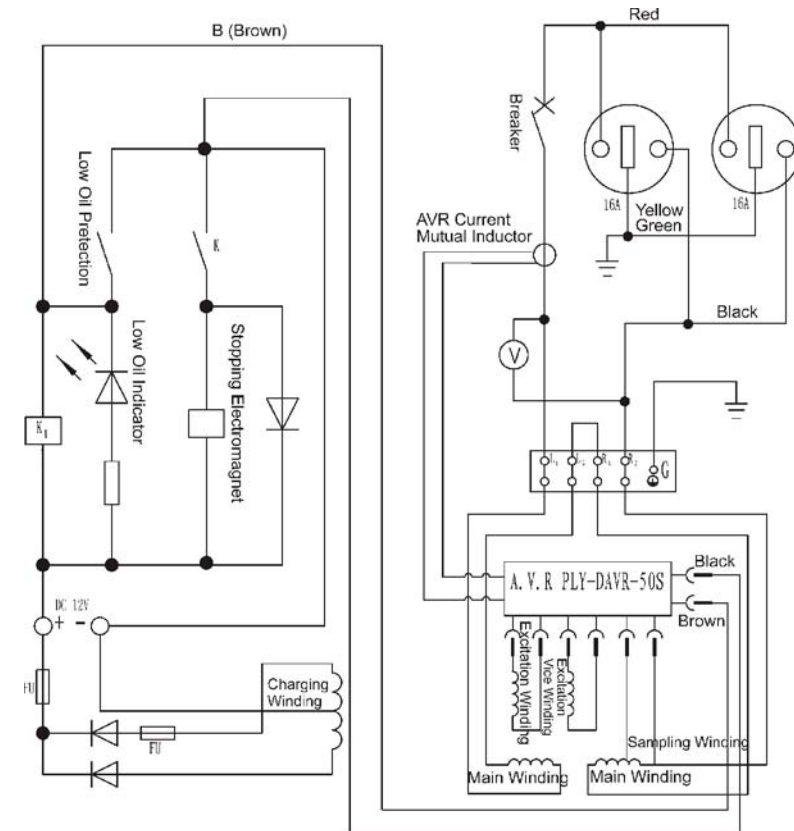



# 11. INTELLIGENT PANEL FUNCTIONS

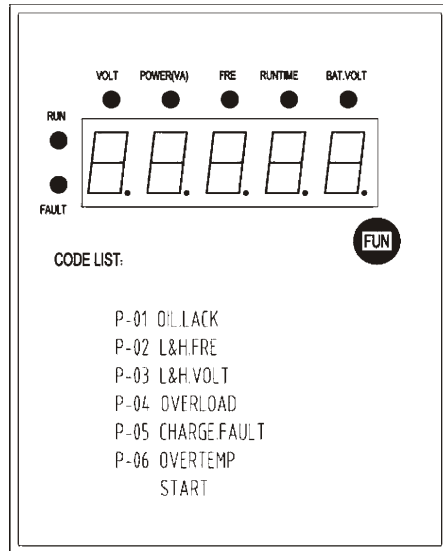

Indication lamp functions:

VOLT: Indicating generator output voltage

PORER (VA): Indicating generator output power

FRE: Indicating generator frequency

RUNTIME: Indicating generator total runtime

BATVOLT: Indicating battery voltage

Button function:

FUN: Switching indicating content on the display. Including output voltage, output power, frequency, total runtime and battery voltage.

6.3 Electrical appliance particularly motor-driven equipment will produce very high current while starting, the below table provides the reference for connecting these apparatus to the generator set.

TYPE	WATTAGE		TYPICAL APPLIANCE	EXAMPLE		
	STARTING	RATED		APPLIANCE	STARTING	RATED
<ul style="list-style-type: none"> <li>Incandescent lamp</li> <li>Heating appliance</li> </ul>	X1	X1	Incandescent lamp TV	Incandescent lamp 100W	100VA (W)	100VA (W)
<ul style="list-style-type: none"> <li>Fluorescent lamp</li> </ul>	X2	X1.5	Fluorescent lamp	Fluorescent lamp 40W	80VA (W)	60VA (W)
<ul style="list-style-type: none"> <li>Motor-driven equipment</li> </ul>	X3~5	X2	Refrigerator Electric fan	Refrigerator 150W	450-750VA (W)	300VA

## 7. STOP YOUR GENERATING SET

1. Disconnect the load from the generating set.
2. Turn off the air switch of the generating set.
3. Set the speed lever at "RUN" position, run the generating set without load for about 3 minutes. Do not stop the engine suddenly, otherwise the temperature will increase abnormally, the nozzle will be blocked and the generating set will be damaged.

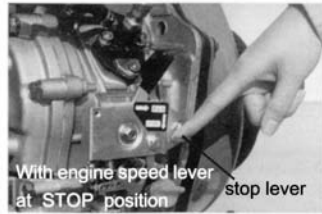

- Press down the stop lever.
- Concerning the electric starter, turn the key to "OFF".
- Turn the fuel cock lever to "S" position.
- Pull out the recoil starter handle until you feel resistance (at this position, both intake/exhaust valve are closed.) and leave the handle in this position. This prevents the engine from rust.

### WARNING

- If the engine keep on running even after the speed lever is placed at the "STOP" position, either turn the fuel cock to the "CLOSE" position or loosen the nut of high pressure fuel pipe on the pump side to stop the engine.
- Do not stop the engine with the decompression lever.
- Do not stop the generating set with load. Stop it after the load removed.

## 10. TROUBLESHOOTING AND REMEDY

Fault Cause	Remedy
Fuel oil is not sufficient	Refill the fuel oil
Fuel cock is not at ON position	Turn it to ON position
Fuel injection pump and nozzle do not delivery the fuel or delivery in-sufficient fuel.	Remove the nozzle and repair it at test table.
The governor lever is not at RUN position.	Set the lever to RUN position.
Check the engine oil level.	The specified oil level should be between the upper level and lower level.
The nozzle has dirty.	Clean the nozzle
The speed and force to full the recoil starter are not enough.	Start the engine according to the start procedures included in this book.
The battery has no electricity.	Charge it or replace it with a new one.
Main switch not be turned on.	Turn the main switch to ON position.
The carbon brush already worn.	Replace the carbon brush.
The contact of the socket is not good.	Adjust the socket.
The diesel engine can not start	
The generating set can not generate	

## 9. LONG-TERM STORAGE

If store the generating set for long periods, make the following preparations.

1. Operate the engine for about 3 minutes and then stop.
2. Stop the engine. Drain the engine oil while the engine is still warm and fill with fresh oil.

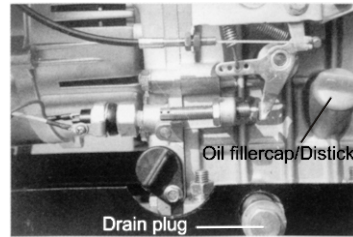

3. Remove the screw plug on the cylinder head cover and refill 2cc engine oil, then put the plug in place.
4. ■ Recoil starting:  
Push the decompression lever down (Non-compression position) and hold it while you pull the recoil starter 2~3 times. (Do not start the engine.)  
■ Electric starting:  
Turn the engine 2~3 seconds with the decompression lever set at the non-compression position, and the starting key at the "START" position. (Do not start the engine.)
5. Pull the decompression lever up. Pull the recoil starter slowly. Stop when you feel resistance. (at this position, both intake/exhaust valves are closed to prevent the engine from the rust.)
6. Wipe off the oil and dirt from the engine and store in a dry place.

## 8. PERIODIC CHECK AND SERVICE

Periodic check and service are very important for keeping the engine in good condition and durable. The chart below indicates what checks to make and when to make them.

### ⚠ WARNING

- Shut off the engine before performing any service. If the engine must be run, make sure the area is well ventilated. The exhaust contains poisonous carbon monoxide gas.
- After the generating set has been used, clean it immediately with a cloth to prevent corrosion and to remove sediment.

Item \ Intervals	Every day	First month or 20 Hrs	Third month or 100 Hrs	sixth month or 500 Hrs	Every year or 1000 Hrs
Check and refill fuel oil	○				
Drain out fuel oil		○			
Check and refill engine oil	○				
Check for oil leakage	○				
Check and tighten fastening parts	○			● Tighten the cylinder head bolts	
Replace engine oil		○ (First time)	○ (Second time)		
Clean engine oil filter				○ (Replace if necessary)	
Replace air cleaner element	(Service more frequently when used in dusty areas)			○ (Replace)	
Clean fuel oil filter				○	● (Replace)
Check fuel injection pump				●	
Check nozzle				●	
Check fuel pipe				● (Replace if necessary)	
Adjust clearance of intake/exhaust valves		● (First time)		●	
Grind intake/exhaust valves					●
Replace piston ring					●
Check battery electrolyte	Every month				
Check carbon brush and slip ring				●	
Check insulation resistance	The generating set has been stored more than 10days ○				

Note: "○" indicates that special tools are required, please contact with agent.

### 8.1 Replace engine oil

Remove the oil filler cap. Remove the drain plug and drain the old oil while the engine is still warm. The plug is located on the bottom of the cylinder block. Tighten the drain plug and refill with the recommended oil.

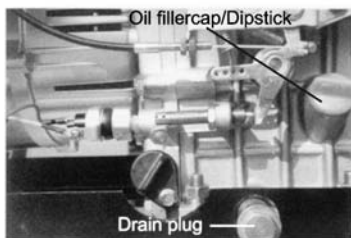

### 8.2 Clean the engine oil filter

Cleaning time	Every 6 months or 500 hours
Replace if necessary	

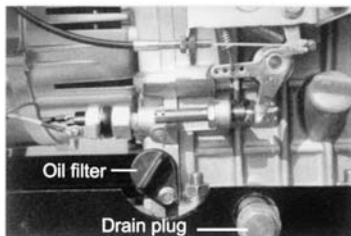

### 8.3 Replace the air cleaner element

Do not clean the air cleaner element with detergent.

Replace time	Every 6 months or 500 hours
--------------	-----------------------------

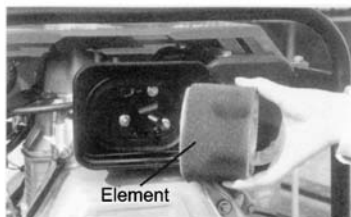

**CAUTION**

- Never run the engine without the element or with a defective element.

### 8.4 Clean and replace fuel oil filter

The fuel oil filter also has to be cleaned regularly to insure maximum engine output.

Clean time	Every 6 months or 500 hrs
Replace time	Every year or 1000 hrs

1. Drain out the fuel from the fuel tank.

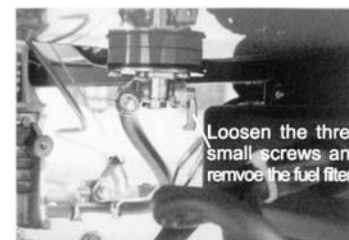

2. Drain out the fuel from the fuel tank.  
Screw off the small screw of the fuel cock and pull out the filter from the filler port, wash the filter thoroughly with diesel fuel.
3. Loosen the fastening nut, bottom cover and delivery discs for cleaning the deposit carbon.

### 8.5 Tighten cylinder head bolt

Tightening the cylinder head bolt requires a special tool. Do not try yourself. Contact with agent.

### 8.6 Check the injection nozzle and fuel injection pump

1. Adjust the clearance of the intake/exhaust valves.
2. Grind the intake/exhaust valves.
3. Replace the piston ring.

**WARNING**

- Do not perform the injection nozzle test near an open fire or any other kind of fire. The fuel spray may ignite. Do not expose bare skin to the fuel spray. The fuel may penetrate the skin and cause injury to the body. Always keep your body away from the nozzle.

### 8.7 Check the generating set carbon brush and slip ring

Often check the generating set carbon brush and slip ring. Readjust if there is spark.